

# Threshold 2,4-D Concentrations for Control of Eurasian Watermilfoil and Sago Pondweed

HOWARD E. WESTERDAHL

Research Ecologist,  
Environmental Laboratory,  
USAE-Waterways Experiment Station,  
Vicksburg, MS 39180

JERRY F. HALL

Plant Ecologist,  
Environmental Laboratory,  
USAE-Waterways Experiment Station,  
Vicksburg, MS 39180

## ABSTRACT

The minimum sustained (threshold) concentrations of 2,4-dichlorophenoxy acetic acid (2,4-D) required to control the growth of Eurasian watermilfoil (*Myriophyllum spicatum* L.) and Sago pondweed (*Potamogeton pectinatus* L.) was determined. A diluter system was developed to deliver five different concentrations of 2,4-D to five sets of four test aquaria. Each aquarium contained meristematic cuttings of *M. spicatum* and germinated tubers of *P. pectinatus* planted in beakers containing standardized sand: peat mixtures. Plant injury was assessed during 11 weeks of continuous exposure to the various 2,4-D concentrations. The 2,4-D threshold concentrations required to control *M. spicatum* and *P. pectinatus* were between 0.10 to 0.25 mg/l, respectively.

## INTRODUCTION

Excessive growth of nuisance aquatic plants is becoming a serious problem for resource managers of recreational lakes, waterways, and other aquatic environments. Chemical control techniques are most commonly used by the Corps of Engineers (CE) field offices with active aquatic plant control programs.<sup>1</sup> The increased environmental awareness over the past 10 years, the strict environmental acts proposed by the EPA, and the recent development of controlled-release (CR) herbicide formulations requires research to determine the minimum sustained (threshold) herbicide concentrations required under short or long term treatment conditions for controlling aquatic plants.

A potential approach to maximizing the effectiveness of aquatic herbicides is by incorporating the respective herbicide in a CR formulation. The concept of the CR formulations is to allow a prolonged exposure of target aquatic plants to a sustained low concentration of a given herbicide. The effective use of CR formulations for aquatic plant

control will likely be achieved at relatively low cost when considering the longevity of the treatment.

Determination of the threshold herbicide concentration required for controlling different nuisance aquatic plants is necessary for developers of CR formulations to produce or modify existing CR systems to provide the best release rates. Similarly, the release rate of each herbicide from the CR formulation and threshold herbicide concentration in the water are important considerations for determining field application rates and treatment costs associated with CR herbicide formulations. Hence, this study focused on the determination of the minimum sustained 2,4-D concentration required to control *M. spicatum* and *P. pectinatus*. This concentration is here defined as the threshold 2,4-D concentration.

After nearly 40 years since its discovery, the specific mode of action of 2,4-D is still unclear. The uptake of 2,4-D by plants has been reviewed extensively (1, 2, 3, 4) and two pathways were found for its entrance into plants, one hydrophilic and the other lipophilic. At relatively low doses, 2,4-D translocates throughout the above and below ground plant tissue thereby being able to kill entire plants. The degradation of 2,4-D by higher plants and microorganisms, as well as degradation and depuration by animals, has been extensively reviewed by many researchers (5, 6, 7).

## MATERIALS AND METHODS

This diluter system delivers exact concentrations of a specific herbicide to 24 aquaria (Figure 1). Each herbicide concentration is maintained in four aquaria. The automatic and reliable production and maintenance of prescribed herbicide dilutions permits testing to determine the threshold herbicide concentration required to control each target aquatic plant.

The following description and reference to Figure 1 will explain the basic components of the diluter system and their function. The Data Trak controller (A) is a programmable microprocessor which controls all of the key components of the system. The diluter system is operated via a 24-v dc battery supply and therefore unaffected by

<sup>1</sup>Dardeau, E. A., Jr., and E. A. Hogg. 1981. Inventory and Assessment of aquatic plant management methodologies. Technical Report A-81- , U.S. Army Engineer Waterways Experiment Station, Vicksburg, MS. In press.

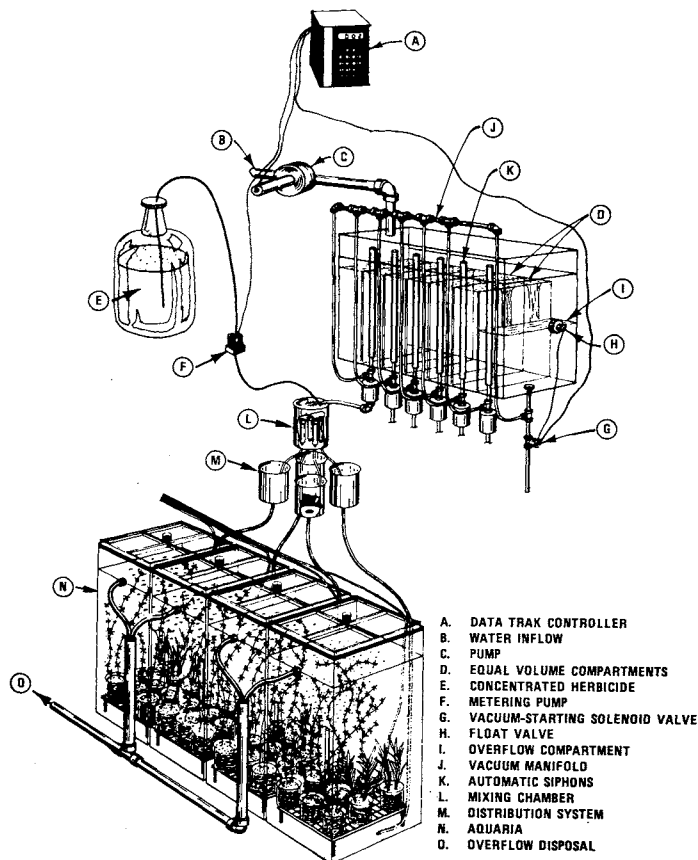

Figure 1. Schematic of diluter system.

power interruptions to the facility. The influent water (B) is pumped (C) from a stainless steel tank to the acrylic compartmented chamber (D). Following the filling of each compartment, selected quantities of the concentrated herbicide solution (E) are pumped, using Valcor, Inc. SV-500 series metering pumps (F), to the mixing chamber (L). The vacuum-starting solenoid valve (G) is opened via an electrical impulse from the float valve (H) when the overflow compartment (I) is filled. This allows water from the overflow compartment to drain and thereby exert a reduced pressure on the vacuum manifold (J) and siphon locks (K), which causes the water within each compartment (D) to be pulled up and over the outlet of each automatic siphon. The siphon breaks after each compartment empties. The water from each compartment flows into a 4 stainless steel mixing chamber (L). The previously added concentrated herbicide solution is completely mixed by the inflowing water to this canister. Four automatic siphons within each mixing chamber operate simultaneously when the can (L) fills with water. The desired herbicide dilution flows out of the overflow siphons into four 1l stainless steel cans comprising the distribution system (M). The desired herbicide dilution proceeds to each aquarium (N), respectively, via gravity flow out of these containers.

Currently, the modified diluter system is capable of delivering during each cycle 1-1 water volumes to each of the 24 glass aquaria, each of which have a volume of 50l (76 cm high x 30 cm long x 30 cm wide). The entire cycle repeats every 30 min, 24-hr per day for a designated

time period. Longer cycle times can be programmed into the Data Trak controller. The amount of concentrated herbicide added to the mixing cans can be varied by programming the desired number of pumping strokes into the Data Trak controller; however, adequate recycling time for the system must be allowed, i.e., 10 min. The modified diluter system and aquaria are located in a controlled-environment greenhouse with supplemental lighting provided by a Sunbrella Fixture, Inc. light bank suspended 1.3 m above the aquaria. The light bank consisted of 12 high intensity discharge (HID) lamp fixtures each containing two 400 watt lamps: one a Lucalox High Pressure Sodium Lamp and the other a Multivapor bulb. Photosynthetically active radiation (PAR) representing the 400-700 nm wavelengths was measured above several aquaria using a Lambda, Inc. PAR meter. The mean PAR received by the aquaria was approximately  $1600 \mu\text{E m}^{-2}\text{S}^{-1}$  which corresponds to 75 percent of solar noon sunlight received at this latitude.

The herbicide solution entered each of the aquaria at the bottom and was circulated through by a pumping-action created by bubbling air up an acrylic standpipe 30 cm long x 1.7 cm diam. Air was injected through an air stone diffuser at the bottom of the standpipe, causing water and the injected herbicide solution to be circulated up through the standpipe. Continuous recirculation of water up the standpipe ensured thorough herbicide mixing in each aquarium, based on preliminary dye studies. Overflow from each equarium passed through a carbon absorption tank to remove the residual herbicide prior to disposal (O).

Based on previous laboratory research<sup>1</sup> the 2,4-D concentrations selected were 0.00, 0.03, 0.05, 0.10, and 0.25 mg/l. A simple randomized experimental design was used to assign each 2,4-D concentration to each of four replicate aquaria. The test aquaria were wrapped in black plastic so that only light from the overhead light bank was allowed to enter from the top of the aquaria. Air temperature in the controlled-environment greenhouse was maintained at approximately 24°C.

The water used for operating the diluter system was uncontaminated tapwater originating from a deep well supply used by Vicksburg, MS, that had passed through activated charcoal and a  $0.45 \mu$  cartridge filter. Water temperature was maintained at  $25 \pm 2^\circ\text{C}$  throughout the study.

Mature plants of *M. spicatum* were obtained from Lake Seminole near Chattahoochee, Florida. Ungerminated tubers of *P. pectinatus* were obtained from Wildlife Nurseries, Inc. in Oshkosh, Wisconsin. A stock culture of *M. spicatum* was developed in reconstituted hard water (8) using a standard hydrosol containing by volume 70 percent washed sand and 30 percent Michigan peat as a planting medium. Approximately 4 weeks prior to testing, four 15-cm meristematic cuttings of *M. spicatum* were planted in each 250-ml glass beaker by burying the cut end of the plants approximately 5 cm in the hydrosol. A finely sieved, washed sand was placed over the hydrosol to an

<sup>1</sup>Westerdahl, H. E., R. E. Hoepfel, E. Hummert, and L. Williams. 1981. Estimation of the 2,4-D Threshold Concentration for Controlling Select Aquatic Macrophytes—Pilot Study. Technical Report A-81- , U.S. Army Engineer Waterways Experiment Station, Vicksburg, MS. In press.

approximate depth of 2 cm to prevent peat fragments from floating into the overlying water. Four ungerminated tubers of *P. pectinatus* were planted in each beaker and covered with 3 cm of hydrosol and 2 cm of fine sand. Five beakers each of *M. spicatum* and *P. pectinatus* were placed in the designated aquaria. During these 4 weeks only water flowed through the aquaria to permit root development and acclimation of the plants prior to exposure to 2,4-D.

Herbicide residue analyses were performed using approved, standard procedures (9) by the Tennessee Valley Authority, Laboratory Branch, in Chattanooga, TN. Water samples for 2,4-D analysis were obtained on day 4, 14, 31, 45, 56, and 77 following initiation of the experiment. Inflow and outflow samples were collected from each aquarium (Table 4). At the end of 11 weeks, the aquaria were dismantled and the remaining plants were removed from each beaker by washing the hydrosol with deionized water. Shoots and roots of each *M. spicatum* plant within a beaker were separated and dried at 70C for 36 hr and weighed. Plants of *P. pectinatus* were not divided into shoots and roots because additional rhizomes developed within the same and adjacent beakers making it difficult to identify the original plants.

The mean shoot and root biomass, expressed as dry weight and representing the four replicate aquaria, were computed for each 2,4-D concentration and compared to the reference aquaria. These results assisted in determining the estimated threshold 2,4-D concentration when considered with the plant injury data. Height measurements of the tallest *M. spicatum* shoot per beaker in each aquarium were recorded initially and at weekly intervals thereafter. The purpose was to measure growth effects on the plants resulting from constant exposure to various 2,4-D concentrations.

Data were statistically evaluated by Analysis of Variance as a test of differences between means. Duncan's multiple-range test (10) was used to make comparisons among the shoot and root biomass means for each of the various 2,4-D concentrations. Dunnett's test (11) was used to compare all experimental means with reference means. Mean plant height data for each 2,4-D concentration were compared to the plant height means from the reference aquaria. Mean shoot and root biomass data were also compared to the biomass means from the reference aquaria.

TABLE 1. MEAN MAXIMUM SHOOT HEIGHT (CM) OF *M. Spicatum* EXPOSED TO VARIOUS CONTINUOUS 2,4-D CONCENTRATIONS.

2,4-D Concentrations mg/l	Day										
	1	7	14	21	28	35	42	50	56	63	70
Reference	22.0 ±1.5	27.1 ±1.0	27.5 ±1.1	28.6 ±0.9	32.7 ±1.3	31.2 ±1.6	33.9 ±1.7	35.9 ±1.7	37.2 ±2.0	38.7 ±2.3	38.3 ±2.2
0.03	27.7 ±1.9	30.9 ±2.0	31.1 ±2.7	35.9 ±2.2	36.2 ±2.5	35.6 ±2.3	34.5 ±2.2	35.4 ±2.4	38.8 ±2.2	39.5 ±2.8	39.5 ±2.8
0.05	23.5 ±1.8	26.9 ±2.1	27.6 ±2.3	29.4 ±2.6	30.9 ±2.5	30.6 ±2.7	29.6 ±2.8	31.3 ±2.7	31.7 ±2.8	32.2 ±3.0	31.6 ±3.3
0.10	22.8 ±2.4	26.7 ±1.6	22.6 ±1.2	21.5 ±1.7	22.5 ±1.9	19.1 ±1.8	20.7* ±2.0	20.7* 2.0	20.5* ±2.1	20.6* ±2.3	20.2* ±2.2

± Standard error of mean.

\*Significant at 0.05 level as determined by Duncan's Multiple Range Test. Each value is the mean of 20 replicate samples.

## RESULTS AND DISCUSSION

Weekly measurements of the maximum *M. spicatum* shoot length per beaker in each aquarium provided an estimate of growth inhibition resulting from exposure to different 2,4-D concentrations (Table 1). When compared to the reference, inhibition of growth as evident by plant height was statistically significant only at the 2,4-D concentration of 0.10 mg/l. This inhibition first became evident on day 35 of the experiment.

Table 2 illustrates the effects of various 2,4-D concentrations on shoot and root biomass of *M. spicatum* following an 11-week continuous exposure to 2,4-D. At a 2,4-D concentration of 0.03 mg/l there was a 28 percent reduction in shoot biomass and a 23 percent reduction in root biomass compared to the reference. At a 2,4-D concentration of 0.05 mg/l there was a 44 and a 54 percent reduction in shoot and root biomass, respectively. At a 2,4-D concentration of 0.10 mg/l there was a 71 percent reduction in shoot biomass and a 77 percent reduction in root biomass as compared to the reference. Shoot biomass values at all three treatment concentrations were statistically different from the shoot biomass value of the reference. The 2,4-D concentration of 0.10 mg/l was the only treatment level having a root biomass value significantly different than that of the reference.

At a 2,4-D concentration of 0.03 mg/l there was a 19 percent reduction in total biomass of *P. pectinatus* (Table 3). At a 2,4-D concentration of 0.05 and 0.10 mg/l there was a reduction in total biomass of 36 percent and 51 percent respectively. At a 2,4-D concentration of 0.25 mg/l there was a 60 percent reduction in total biomass compared to

TABLE 2. ROOT AND SHOOT BIOMASS OF *M. Spicatum* FOLLOWING 11 WEEK CONTINUOUS EXPOSURE TO THREE 2,4-D CONCENTRATIONS.<sup>a</sup>

2,4-D Acid mg/l	Biomass (gm)	
	Shoots	Roots
Reference	1.04 ± 0.07	1.17 ± 0.13
0.03	0.75 ± 0.05*	0.90 ± 0.19
0.05	0.58 ± 0.06*	0.54 ± 0.06
0.10	0.30 ± 0.06*	0.27 ± 0.05*

<sup>a</sup>Expressed as dry weight, mean ± standard error, n = 20.

\*Significant at 0.05 level as determined by Duncan's Multiple Range Test.

TABLE 3. TOTAL BIOMASS OF *P. Pectinatus* FOLLOWING 11 WEEK CONTINUOUS EXPOSURE TO FOUR 2,4-D CONCENTRATIONS.<sup>a</sup>

2,4-D Acid mg/l	Total Biomass (gm)
Reference	0.86 ± 0.02
0.03	0.70 ± 0.01
0.05	0.55 ± 0.02*
0.10	0.42 ± 0.009*
0.25	0.34 ± 0.008*

<sup>a</sup>Expressed as dry weight, mean ± standard error, n = 20.

\*Significant at 0.05 level as determined by Duncan's Multiple Range Test.

TABLE 4. MEAN 2,4-D INFLOW CONCENTRATION FOR 11 WEEK STUDY PERIOD.

Mean 2,4-D Concentration (mg/l)	Standard Error of Mean <sup>a</sup>
0.03	0.004
0.05	0.005
0.10	0.010
0.25	0.003

<sup>a</sup>Number of samples, n = 6.

the reference. Total biomass was significantly different from the reference at all 2,4-D concentrations except for the 0.03 mg/l treatment.

Regression analysis was used to compare the percent injury incurred by *M. spicatum* and *P. pectinatus* when exposed continuously to the selected 2,4-D concentrations (Figures 2 and 3). The best-fit regression equation ( $y = bx$ ) was used to estimate the time required to produce 50 percent injury for each 2,4-D concentration. The minimum length of time required to produce 50 percent injury to *M. spicatum* was approximately 3.5 weeks with a continuous exposure to 0.03 to 0.05 mg/l of 2,4-D and 1 week with 0.10 mg/l of 2,4-D. For *P. pectinatus*, this time period was approximately 10 weeks with 0.05 mg/l, 3 weeks with 0.10

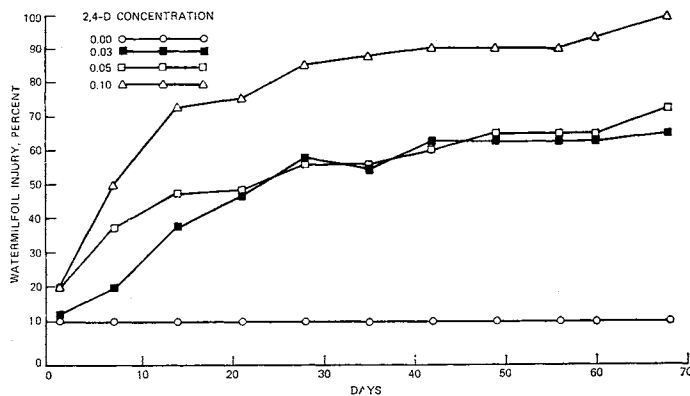

Figure. *Myriophyllum spicatum* L. response to three treatment concentrations of 2,4-D over an 11-week study period.

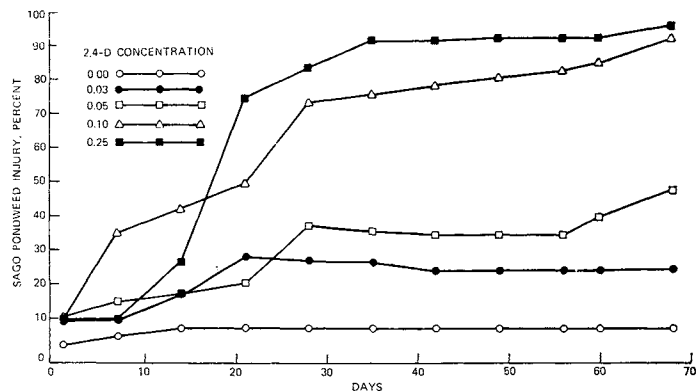

Figure 3. *Potamogeton pectinatus* L. response to four treatment concentrations of 2,4-D over an 11-week study period.

mg/l, and slightly less than 3 weeks with 0.25 mg/l of 2,4-D. The 2,4-D threshold concentrations required to control *M. spicatum* and *P. pectinatus* were determined to be 0.05 to 0.10 mg/l and 0.10 to 0.25 mg/l, respectively. These results are similar to those observed in the pilot study.

#### ACKNOWLEDGMENT

The tests described and the resulting data presented herein, unless otherwise noted, were obtained from research conducted under the Aquatic Plant Control Research Program of the United States Army Corps of Engineers by the USAE Waterways Experiment Station.

#### LITERATURE CITED

- Jansen, L. L. 1964a. Surfactant enhancement of herbicide entry. *Weeds*. Vol. 12, pp. 251-254.
- Jansen, L. L. 1964b. Relation of structure of ethylene oxide ether-type nonionic surfactants to herbicidal activity of water-soluble herbicides. *J. Agric. Food Chem.* 12:223-227.
- Jansen, L. L. 1965a. Effect of structural variations in ionic surfactants on phytotoxicity and physical-chemical properties of aqueous sprays of several herbicides. *Weeds*. 13:117-123.
- Jansen, L. L. 1965b. Herbicidal and surfactant properties of long-chain alkylamine salts of 2,4-D in water and oil sprays. *Weeds*. 13:123-130.
- Ashton, F. M., and A. S. Crafts. 1981. *Mode of Action of Herbicides*. John Wiley and Sons, New York. pp. 272-302.
- Loos, M. A. Phenoxyalkanoic acids. In: *Herbicides*, Vol. 1, P. C. Kearny and D. D. Kaufman, Eds., Marcel Dekker, New York, pp. 1-128.
- Mumma, R. O., and R. H. Hamilton. 1976. Amino acid conjugates. In: *Bound and Conjugated Pesticide Residues*. D. D. Kaufman, G. G. Still, G. D. Paulson, and S. K. Bandal, Eds., (ACS Symp. Ser. 29), pp. 68-85.
- U. S. Environmental Protection Agency. 1975. Methods for acute toxicity tests with fish, macroinvertebrates, and amphibians. EPA-660/3-75-009.
- APHA, AWWA, WPCA. 1976. *Standard Methods for the Examination of Water and Wastewater*, 14th Ed., Amer. Publ. Health Assoc., Washington, D.C.
- Duncan, D. B. 1955. Multiple range and multiple F tests. In: *Biometrics*. 11:1-42.
- Dunnnett, C. W. 1955. A multiple comparisons procedure for comparing several treatments with a control. *J. Am. Stat. Assoc.* Vol. 50, pp. 1096-1121.